



ELKUME e.U.

Ihr Partner für Haus- und Industrie Heiztechnik



Rohrheizkörper

F c \ \ V j n _ " f d y f g b x \ c w j y f x j w h y h ' a y h u i a a u b h r h r ' < y j n y a y b h z x j y u g : ' u m f c \ f z f i b x f c \ f z y i j v y ' < y j n g w \ u b [y b ' g c k j y ' u g] b x j j] x i y ' y ' 6 j y [y z c f a y b ' n i f ' 6 y \ y j n y b j c b ' k u g g y f z x ' z @ z z ; u g c x y f u b x y f y b b j m h _ c f f c g j] y b ' a y x j y b j y f k y b x y h k y f x y b " g y ' k y f x y b ' a] n a c x y f b g h y b k j w y ! z ' 9 j o z ' ! i z j y f x j w h b [g ' i b x ' ; ' \ j y f z a f y b \ y f [y g h r ' h i b x v j y h y b y j b y [i h r ' j y f z c f a v u f _ y j h ' 8 j y j y f k y b x i b [' j c b \ c w k y f h [y a ' - g c ' u h j c b g a u h y f j u [u f u b h y f h y] b y \ c y ' g d y n j z g w y ' 6 y ' u g h i b [g a " [j w _ y j h ' a f y ' a y w u b j g w f c v i g h ' 5 i g z \ f i b [' n y j m b y h g j w ' x i f w ' 9 f g w " h y f i b [g z g h [_ y] h i b x \ c \ y ' g h u b x n y j h y b ' u i g ' " 8 u g j y g \ f [i h z c f a v u f g j b x z _ " b b y b j y f g w j x y b ' @ g b [y b ' z f x j y a y j g h y b ' < y j n u b z c f x y f i b [y b ' u b [y v c h y b k y f x y b ' 8 j y ' < y f g h r ' i b [' y f z c [h b u w ' n y j m b i b [z a i g h y f c x y f b u w ' g w u v c b y [y v c [y b z c x y f u i z k i b g w [' y g h y w h j a ' v j y [y z \] [y b n i g h u b x " f c \ \ v j n _ " f d y f g b x j j y g y] h [' y j b g y m v u f f u g f j d d y b \ y j n f c \ f y y a y b z ' 9 j b g w f u i v \ y j n _ " f d y f i g k " e i b x n y j m b y b j g w v y j g u w [y a } e y f ' 5 b k y b x i b [' x i f w ' y j b y \ c \ y ' @ v y b g x u i y f b j y x f [y j y f v f u i w g k y f h y ' i b x ' c d h j a j y h y ' k j f i b [g f f u x y u i g " a f y b ' 9 j b g u m z j b x y b f c \ \ v j n _ " f d y f \ u i d r g w ' j w ' v y j x y f ' 9 f k j f a i b [' j c b ' @ z z ; u g y b z : ' " g g j [_ y j h y b i b x : y g f g c z y b " > y ' b u w j y f k y b x i b [g r k y w \ k y f x y b i b h y f g w j x ' w y ' a u b h r ' ! a u h y f j u y b j y f k y b x y h k j y . ' 9 x y g h u \ j b j y f g w j x y b y b ' @ y j y f i b [y b z g h u z ' ? i d z y f z a y g g j b [' i b x ' h j h u b ' 8 y f [y k \ ' h y ' a u b h r ' i a g w j y e h y] y b ' k j x y f g h u b x g f u h u i g ' 7 f c a b j w y ' x f u h b j 7 f z x y f j y f k y b x y h r ' - g c ' u h c f u i g a u [b y g j i a c l n x d i ' j y f x u g y j b ' u i g f y n y j m b y h y f k j a y y j h y f i b x [y j m n y j h [' y j b [i h y f y y _ f j g w y f - g c ' u h c f j g h ' " "



= \ f ' 5 b k y b x i b [g w y f j w j g h g \ f j j y z ' h i . ' . ? i b g h g c z j b x i g h f j z ' 5 d d u f u h v u i z < c w j u j i a h r w b j z j y f d u w i b [g a u g w j b y b z h f c w b y b z j c f k j f a y b z z f x y b ' 9 j b v u i ' j b ' b x i g h f j u b u [y b z ' 6 y \ y j n i b [' j c b : c f a y b i b x ' k y f _ n y i [y b z h y a d y f j y f i ; y f j h z < c w j u j i a " z y b z @ u v c f u i g r ' g h i b [y b z f u i a \ y j n [y f j h z @ z h y \ j m y f z ; j y e z c f a y b z k y f _ n y i [y z ; f c e _ w y b z k u g w a u g w j b y b z ; y g w j f f g d ' y f z ' 6 u w ' z y b z ; f j h y i g y b z ? u z z y a u g w j b y b z ; f j ' u d d u f u h y ' i g k " " n i f a c b u j [y x y f f c \ \ v j n _ " f d y f g h \ y b j y f g w j x y b y ' 6 y z g h [i b [g ' a " [j w _ y j h y b n i f j y f z [i b [z k j y ; y k j b x y b j d d y ' f u i z j y " h y z [y g w k y e h z u i z y d y f g g h z : ' u b g w j b j y f g w j x y b y b ' 5 i g z \ f i b [y b ' f a j h i ; y k j b x y z ' g w f u i v i z f i b x i z f y w h r w j [y b ' 6 y z g h [i b [e c x y f a j h h f [y f v y w ' b u w j f y b ' j c f [u y b " "

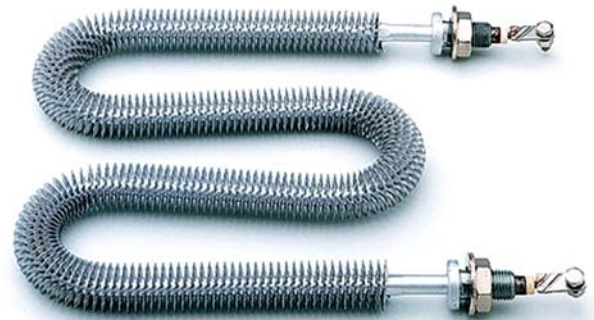

Sie eignen sich besonders zur Erwärmung von:

- € K UggYfV\ \ } Hf
- € x \ } Xyf
- € ; Uj UbjgWY' 6) XYf
- € : c h c [f u z g w y ' 6) XyF
- € 9 g g y b k } f a Yf
- € ; f j [Y f j H y
- € @ z h y \ j m y f
- € K Yf _ n y i [Y
- € < y j e _ u b u j y f h j y f
- € - b ' 5 i a j b j a ' c x y f a y g g j b [[i g g y j b [y v y h y h z f x j y ' _ j i b g h g c z j y f u f v y j h y b x y - b x i g h f j y ' "

Optionen:

- € j y f g w j x y b y ' 7 \ f c a ! B j w y ' ' f c \ f a u b h r ' k y f _ g r c z y ' z f g d y n y ' y ' 9 j b g u m k y w y
- € U g f j d d y b f c \ \ v j n y a y b h
- € _ c a d y h y ' 9 j b g w f u i v \ y j n _ " f d y f
- € U g < y j n z u b g w
- € a j h j b h y [f j y f y f h y a d y f u i f i f y [y i b [' i b x ' g j w y f y j h y a d y f u i f i 6 y [f y b n y f
- € U g @ z h y \ j m y f ' "

@ j g h i b [g a y f _ a u y . ' ' "

- € v j y [y z \] [[y [' \ h z] b x j] x i y ' y : c f a [y v i b [' a " [j w
- € \ c w j y f x j w h y h y ' - g c ' u h j c b z [f c e y ' 6 y f j y v g g j w y f y j h
- € \ c \ y g d y n j z g w y ' c v y f z ' w v y b v y u g h i b [
- € [i h r ' k j f a y y j h z \] [_ y j h

Formen und Arten von Heizelementen

9]b YY_fhgWYg<Y]nY Ya YbhVYgh\h a Y]ghUi gY]bYa cXYf a Y\fyfYb'fc\zf fa [[Yb<Y]ngj] VYZ J YfV]bXi b[ga]Hr'Z f'XYb YY_fhgWYb'5bgW'i gg i bX'X]Y' ?" dZ' cXYf: 'UbgWYb Z f'X]Y' a YWUb]gWY'6YZg]i i b[" 8]Y' <Y]ngj] VY'_" bbYb Y]bYb fi bXZ ZUMWYb'cXYf cj UYa Ei YfgWb]h\UWYbZgc: k]Y XYf' A UbHr' XYg <Y]ngj]UWYg VYgh\hUi gY]bYa 'A YfU'fc\f j cb'gdYn]ZgWYb'8]a Ybg]cbYbZ'X]Y'Ui gY]bYa '[YY][bYHr'b' A UHr]U' [YZ]f]h[h k]fX' '5b[YdUggh'Ub'X]Y' Yk Y]]] Yb' 5bk YbXi b[" 8]Y' CVYfZ] WY'XYg A YfU' a UbHr'g' _Ubb' k Y]Hr'f V\UbXY'hk YfXYbZ'i a 'XYb' l a [YVi b[g'K]XYfg]UbX'ni 'Yf\ ' \Yb' 'Ni' f'J YfVYggYfi b['XYf' K } fa Y' VYf]fU[i b['j cb' @ Zhi bX'; Ug<Y]nY Ya Ybh'vz'_" bbYb X]Yg' a]hY]bYf F]ZY'i b['Ui gY]bYa 'GHU' VUbX' gYb_fYVWhi a 'XYb' <Y]ngj]UW' j Yfg\Yb' k YfXYb'" 9]b[]Y' <Y]nY Ya Ybh'Z' f'VYgcbXYfY' Nk YWY'_" bbYb]b' Y]bY [Yk' " bgW]Hr' : cfa []Y [cggYb' k YfXYb Z f'X]YgYb' Nk YW' k]fX' a Y]gh'bg' 5' i a]b]i a ' j YfYb XYh k]fX'" 8]Y' J YfV]bXi b[] j ca '<Y]hXfU\hri 'XYb' 5bgW'i gg X]Y' Ug' ? UY' cXYf GWfU' V' J YfV]bXi b['VYZ]bXYhg]W']bbYf\UV' XYg A YfU' fc\Yfg']a ']gc']YfYbXYa 'A UHr]U'" 8Ug Fc\ f' k]fX' XUb] j Yfg]Y[Y'hi bX' j Yfg]W' cggYbZgc' XUgg' U' Y' U']h' Yb H]Y'Y [F' bX']W' j cb' U' Yb' l a k Y'h 9]bZ' " ggyb [YgW' " hng]bX'" 8]Y' <Y]ngj] VYZ' k]Y' X]Y' [fi bX'Y[YbXYb' gYa] DfcXi '_h_' " bbYb]b' j Yfg]W']XYbYb : cfa Yb j YfUfV]hYh k YfXYbZ' X]Y' XYb' 5bZ' fXYfi b[Yb' XYg? i bXYbZ' U\ } b[] j cb' XYf' YbX[']h[Yb' 5i gg]U]h i b[Z' k c' g]Y' Ub[Yk YbXYh k YfXYb' f]V]g'ni a 'a U]]a UYb' 6Yf]YVgxfi W' j cb' * Z' 'A DU' : g]bX'" 8]Y' YY_fhgWYg<Y]nY Ya Ybh'_" bbYb' cd]h'cbU' a]h' j Yfg]W']XYbYb' 6YZg]i i b[g' 9]Ya Ybh' b' k]Y' : 'UbgWYb Z f'X]Y' a YWUb]gWYb' A cb]U[Y' U] g[Yg]U]Hr' k YfXYb'" Gc' k]Y' a]hY]bYf [YY][bYHr'b' 5bgW'i gg Uf]UbHr' ni a '5bgW'i gg Ub' XYb' Gfca _f]g' U] g[Yg]U]Hr' h'g'Yb'" 5' Y' YY_fhgWYb' <Y]nY Ya Ybh'Yb' k YfXYb' bUW' XYf' Bcfa ' 9B' * \$' ') ! % Yb]k cfZ]b' i bX' \Yf[Yg]Y' H'"

F i bXdfcZ'

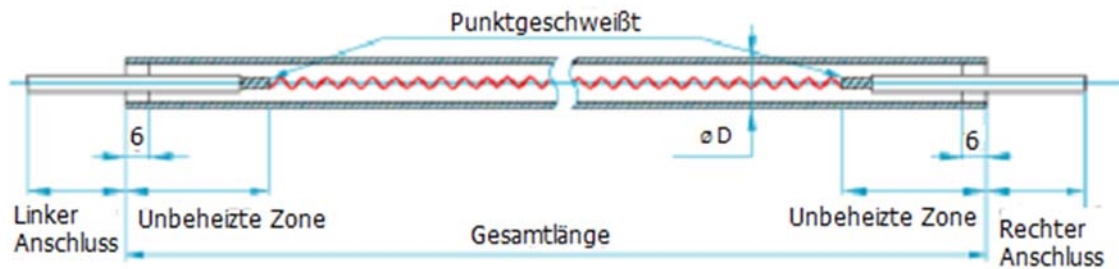

E i YfgWb]hY]bYg[YVc[YbYb F i bXfc\Yg'

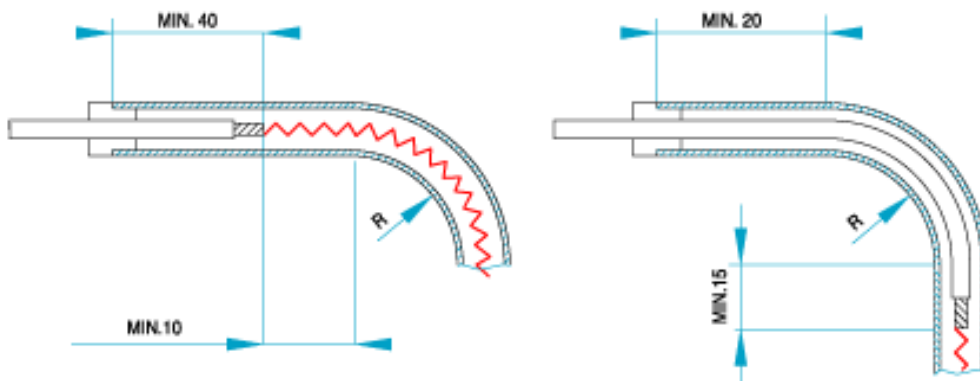

Biegeradius eines Rundrohr Profils

Flach-Oval Profil

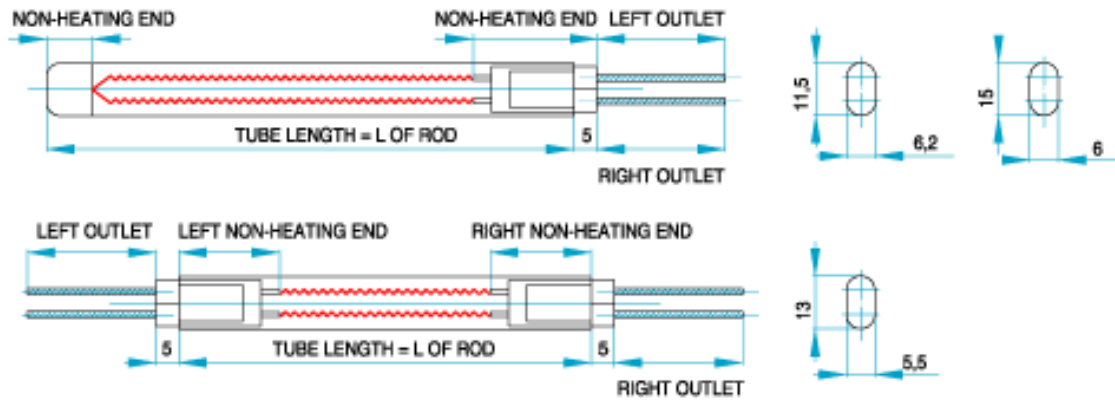

Querschnitt durch einen Flach-ovalem Profil

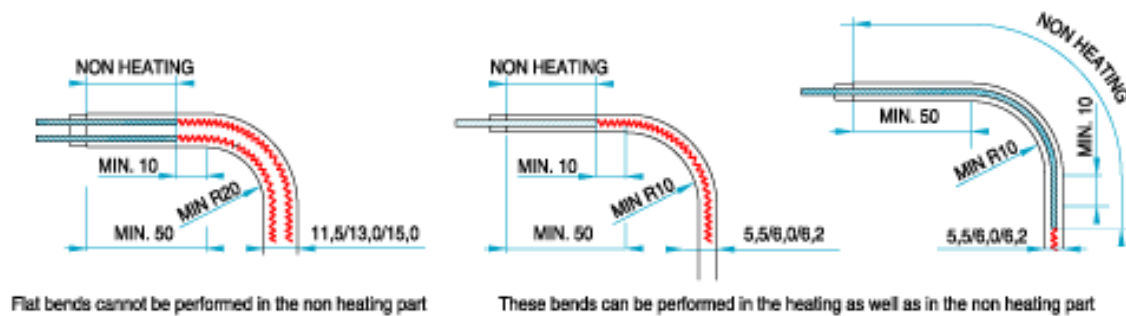

Biegeradius der Flach-ovalem Profil

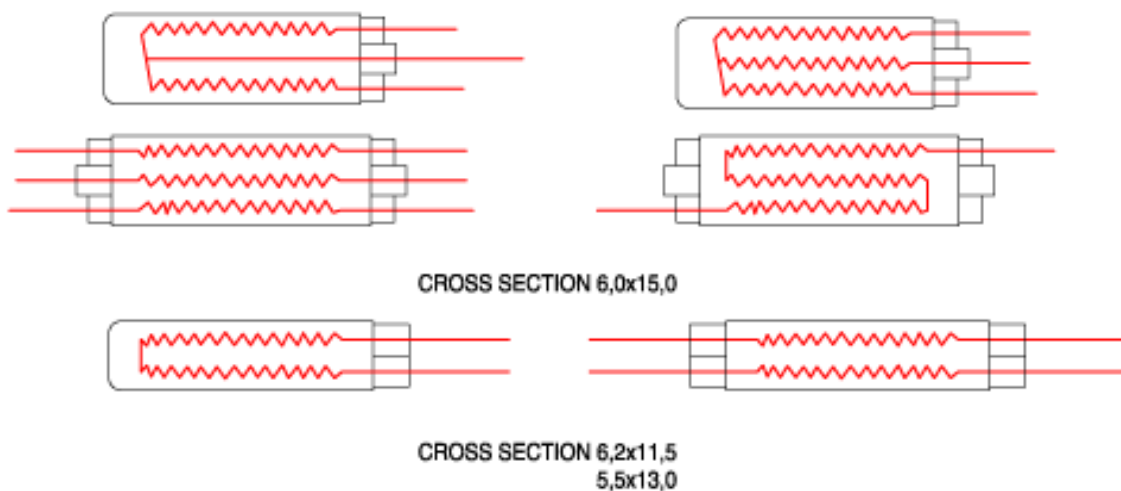

Schematische Anordnung von den Heiz-Spiralen des Widerstandsdrath in Stäben mit einem flach-ovalem Querschnitt

Biegeformen

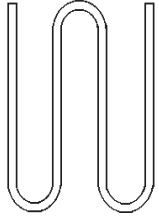
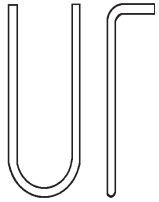
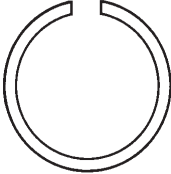
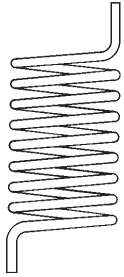
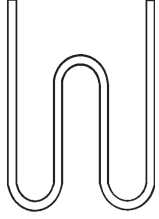
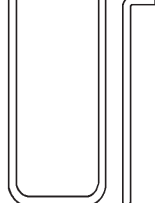
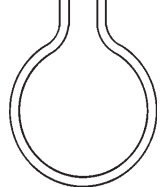
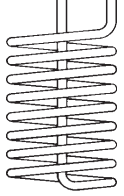
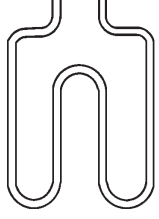
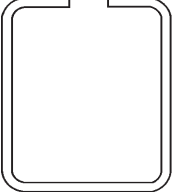
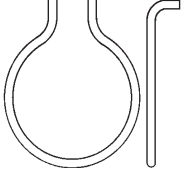
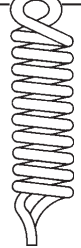
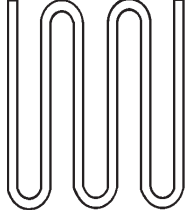
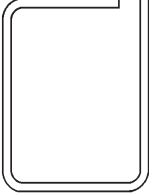
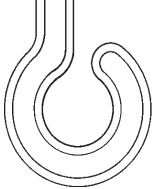
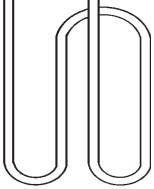
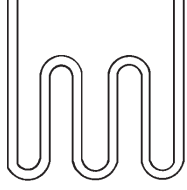
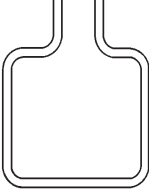
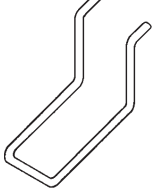
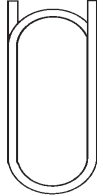
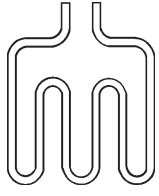
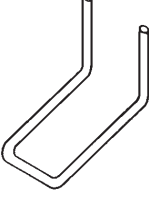
			
			
			
			
			
		<p>Es gibt viele verschiedene Arten, Rohrheizelemente zu biegen. Falls Sie in der Tabelle nicht die Ausführung finden, die Sie benötigen – senden Sie uns doch einfach Ihre eigene Zeichnung.</p>	

Anschlussarten

Ub XYb Y_Y_HfjgWYb Gfca _fYjg gLbX'k JWH[Y 6YgubXhY Y YlbYg YXYb <Y)nY'Ya YbH'g" ÆfY fJWH[Y K U' Z]b yVYfY]bgha a i b['a]hXYa ' <Y)nY'Ya Ybh DUfUa YHf' i bX' Z f'XYb '5bk YbXi b[gWfY]WZ]gh i bYf) gg]W' Z f'X]Y' _cFFY_H' i bX' gWYfY' 6YX]Ybi b['XYg <Y)nY'Ya Ybfg]b Y]b : Yf) H'

< } i Z[j Yfk YbXYH' 5bgW' i ggUfHYb'

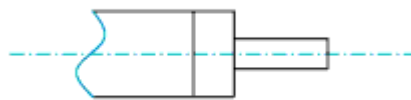

5i g[Ub[gD]b''

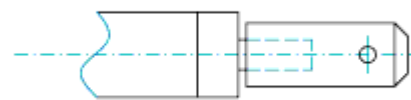

: 'UWghWYfz 8]a Ybgcb '*Z'

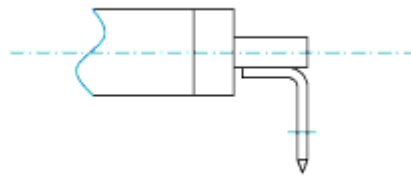

: 'UWghWYfz 8]a Ybgcb '*Z''

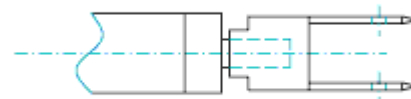

8cddY': 'UWghWYfz 8]a Ybgcb '*Z'

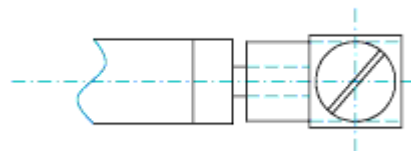

5bgW' i ggGcWY'' a]hA ('cXYf'
A) GWfU i V_ Ya a Yb

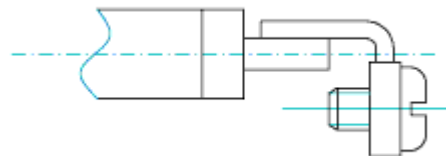

; YVc[YbYf 5bgW' i ggGcWY'' a]h
A (GWfU i V_ Ya a Yb

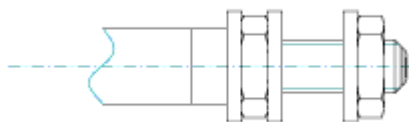

A ('cXYfA) ; Yk]bXY 5bgW' i gg'' a]h
A i HfYfb i bX' i bhYfY[gWY]VYb'

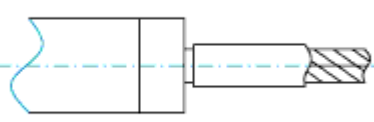

GHubXUFX! 5bgW' i gg a]h@]nYb'

Anschlussarten

5bgW'i gg'9Ya Ybh'Z f'GH'V' a]hcj U'Ya 'Ei YfgWb]Hh

5i g[Ub[g]@mYb j cb [YY][bYHb @ b[Yb'g]bX'U'g J YfV]bXi b[gY'Ya Ybh']b' GHUb[Yb' a]hZUM! c] U'Ya 'Ei YfgWb]Hh] Yfk YbXYH' 5V\ b[] j cb XYf' 6Yf]YVgh'a dYfUhi fZA Ygg]b['cXYf B]WY'! 5i g[Ub["' 8]Y' @mYb' _' bbYb' a]h[YY][bYHb' -gc']Yfa UHf]U' U' g[YgUHH'hk YfXYb''

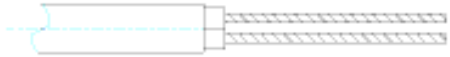
GHUbXUFX! 5i g[Ub[g?UVY'	GHUbXUFX' ?UVY' a UHf]U'	=gc' U]cb'	A U' "' 6Yf]YVgh'a dYfUhi f'f57L'
	A Ygg]b['	!'	% \$'
	A Ygg]b['	g]]WbY'	% \$'
	A Ygg]b['	DH' 9 fHYZcbE'	&* \$'
	A Ygg]b['	?YfUa]_ <' 'gYb'	&* \$'
	b]WY'	!'	(\$\$'
	b]WY'	; 'Ugg'gY]Xyb#G]]_cb'	') \$'
	b]WY'	?YfUa]_ <' 'gYb'	(\$\$'

5bgW'i gg'a]hGW'i m'Y]Hf! ?UVY'

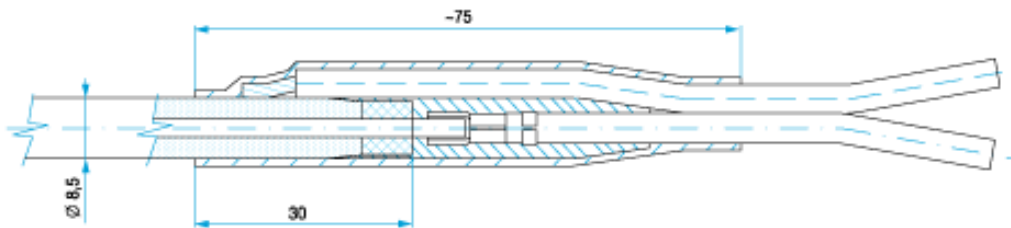

9]b' 9fXi b[g_UVY' U' ZXUg <Y]nY'Ya Ybh'A Ubh' j' Yf'' H'h' _Ubb' cd]hcbU' a]hGW'fi a dZgW' U' W' UV[YXYW]hk YfXYb'

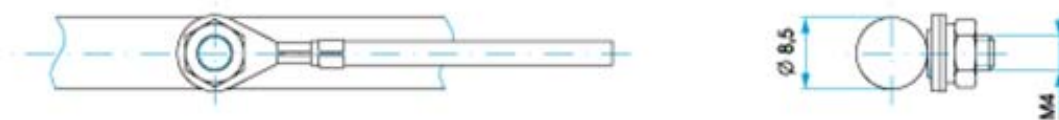

5i ZX'Ya ' <Y]nY'Ya Ybh'Ub[Yg]Wk Y]EHf' ; Yk]bXY! 6c'nYb' a]hY]bYf' A i H'h'f' j' YfVi bXYb''

A cbHU[Y'i bX' 6YZ]gh[i b[gY'Ya Ybh'

8]Y' a Y]ghYb' XYf' <Y]nY'Ya Ybh']g]bX' a]h] YfgW]YXYbYb' A cbHU[Y'i bX' 6YZ]gh[i b[gY'Ya Ybh' 'Z f' X]Y' _c]fY_ H'Y' ;]] Yf] b['WY] XYf' A cbHU[Y']b' XYb' 5b' U[YbZ' Z f' XYb' f]W]h[] Yb' 5Vg]UbX' 'rk]g]WYb' XYb' Y]bnY'bYb' GH' WYb' Y]b]g' 9Ya Ybh'g' U'g] i bh'f]g]i h'i b['cXYf' Yg'gc' "XUg' 5Vg]UW]Yb' "Ub[Yf' <Y]nY'Ya Ybh'Yb' VY] <c]f]ncbHU'Yb' 6Yf]YVgU' Y'

9fa " []W]hY]bY' Y]bZ]UWYb' 9]b] i bX' 5i g]U']' b' 5b' U[Yb' i bX' A Ug]W]bYbZ'k YfXYb' X]Y' <Y]nY'Ya Ybh' 'a]h] YfgW]YXYbYb' 5fHY' j' cb' : 'Ubg]WYbZ' 5bgW' i gg] UH'Yb' 5i g[Yf' gYH' 8]Y' <Yfgh' i b['YfZc' [h]b' XYb' a Y]ghYb' : } "Yb']a' GHUbnj YfZ]A' fYb' XUg' j' Yfk YbXYH' A UHf]U' k]fX' bUW']\Yb' 5b[U]VYb' j' Yfk YbXYHk]Y' GHU' cXYf' 9XY' g]U' " 6' YWY' " 9g'k YfXYb' U' W' UbXYfY' 6YZ]gh[i b[g' : cfa Yb] cb' GHU' cXYf' A Ygg]b[' DfcZ] YZ' cV' fi bX' cXYf' g]W]g]W]] Yb' E i YfgWb]Hh' Ub[YdUgg] 8]Y' C'VYfZ] WY' _Ubb' j' Yf]b]WY' hcXYf' U' W' bUW']\Yb' 5b[U]VYb' WY' \UbXYH'

8]Y' <Y]ng] WY' k YfXYb' a]H'h' g' DfYgg]bZ' @ H'YbZ' ? Ud] " Uf! @ H'Yb' cXYf' GWk Y]EYb' Ub' XYb' <Y]nY'Ya Ybh'Yb']b' GW' i m]Ura' cgd\} fY' VYZ]gh[] H' 8]Y' : 'Ubg]WY' k YfXYb' a]h] XYb' bck' YbX]] Yb' 6YZ]gh[i b[gY'Ya Ybh' fA i H'h'f]bZ' i bh'f]Y[g]WY]YVbZ' GW' fU' VYb' YH'W' U' g[YgUHH'h' 9]b]] Y' : 'Ubg]WY' a]h' ? Ya a Yb' a]h[YY][bYHb' ?' dZ]Z' X]Y' YfZc' fXYf] WY' A UE' Ub' GW' i m]b' XYf' Ub[Y[VYbYb' 6Yf]YVg] a [YVi b['V]YHb' [YgW' cgg]Yb' k YfXYb' _Ubb''

8]Y' Zc' [YbXY' _j' fny' Ni g]Ua a YbZ]Ugg] b['gh' hbi f' X]Y' \} i Z[]ghYb' 6Y]gd] Y' Z' f' : 'Ubg]WY' 9]b' <Y]nY'Ya Ybh' _Ubb' a]h' XY'Ya []YY][bYHb' : 'Ubg]W' U' g] i bgYfYa' Ccf]a Ybh] cb' a \fYfYb' n\A' H'm]Yb' U' g[YgUHH'hk YfXYbZ' Y' bUW' XYb' 5bZc' fXYf] b[Yb' XYg' ? i bXYb'

Anschlussarten

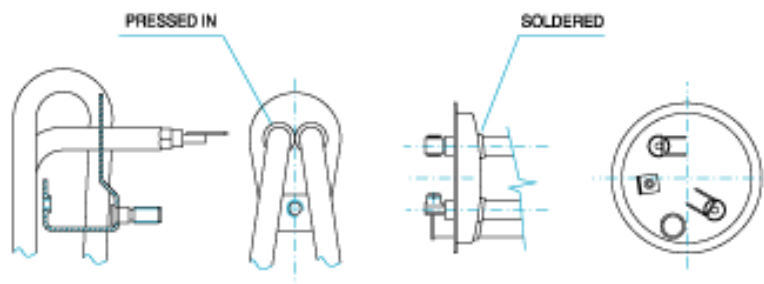
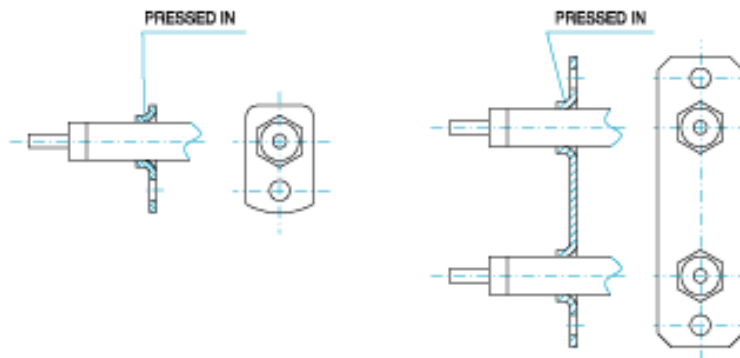

Beispiele für Flansche aus Blech und als Pressteil

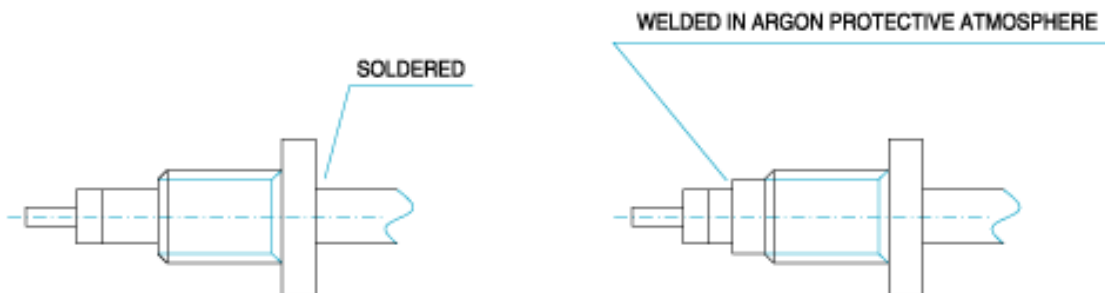

Beispiele für Schraub-Nippel mit Gewinde und Sechskant

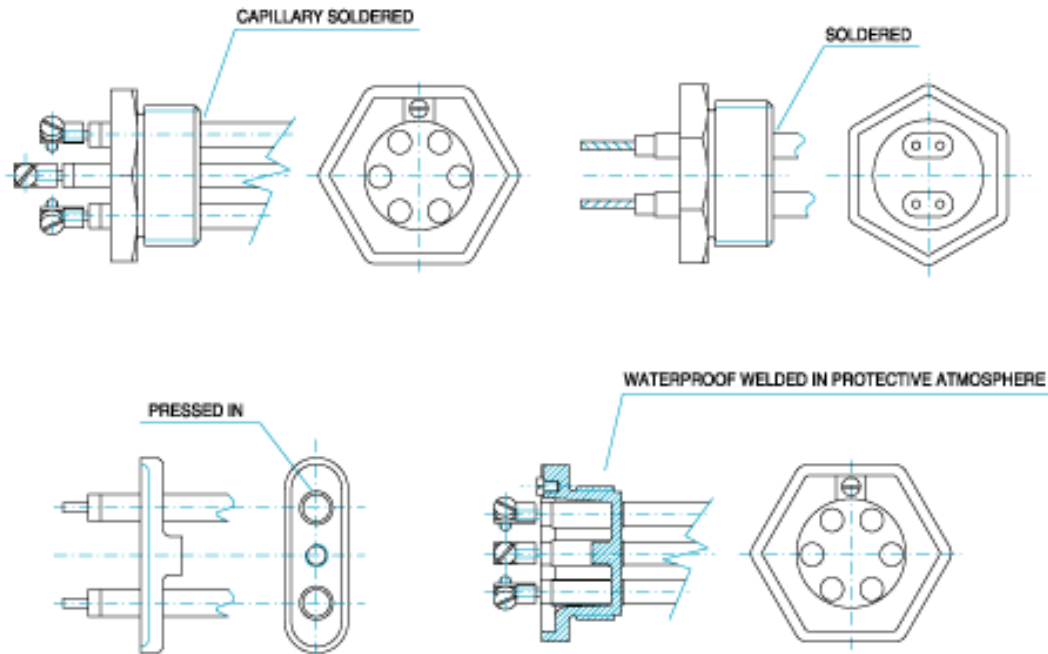

6Y]gd]Y'Y'Z' f'GWa JYXY'cXYf; i ggh]Y''

9][YbgWUZhb XYgJ Yfk YbXYH'b '5i EYb!F c\!A UbH''

A UHvf]U		A U I '' 6YHf]YVg HVa d''F57E'	A Yf_a UY'	Anwendungsbereich
GhU''	% (' ' Gh' (!&	(\$ \$'		@ ZHfk) fa i b['V]g' (\$ \$'s' 7Zx !<Y]ni b[ž U_U]gWY 6) XYfz?cbHU_h<Y]ni b[
9XY'ghU''	%+&(\$ ' %(' \$% ' \$(+) \$'		@ ZHfk) fa i b[ž; Ugz?cbHU_h<Y]ni b[']
9XY'ghU''	%+&(* ' %(' (% ' &%	+) \$'	[i H' ?cfcg]cbgVYgh) bX][_Y]h	9f\]mYb' j cb: '' gg][_Y]Hbz; UgYbz?cbHU_h <Y]ni b[ž-bZUfch<Y]ni b[Ybz; f] 'g'
9XY'ghU''	%+ (- ' %((\$(' %@	+) \$'	GY\ f [i H' ?cfcg]cbgVYgh) bX][_Y]h	8Ua dZ 9fnYi [i b[ž bUgg! 'fcW_Yb' N]f_ i 'U]cb! <Y]ni b[ž<Y]ni b[' j cb \cW 'W'cf]YfhYa 'K Uggyf'
9XY'ghU''	% (, +* ' fHbVcm , \$\$E'	-\$ \$'	<c\Y' ?cfcg]cbgVYgh) bX][_Y]h K]XYfg]UbX žk) fa Y' 6Ygh) bX][_Y]h	K) fa YgdY]WYfZ U[[fYgg] Y: '' gg][_Y]Hb'
9XY'ghU''	%+&) % % (, & ' '\$&6'	-\$ \$'	K) fa Y' 6Ygh) bX][_Y]h	K) fa YgdY]WYf'
?i dZyf B]WY! ?i dZyf	7i !8<D'	&\$ \$'		K Uggyf!<Y]Hfz; YgW]f'fgd'' YfzK UgW'a UgW]bYb'

: 'UW!cj UY DfcZ]Y_' bbYb' V]g]ni 'a U] ja UYb' CWYfz) WYbH'a dYfU] f] j cb)) \$'s' 7 Y]b[Ygyf'rhk YfXYb i bX'g] g]bX i bHf' UbXYfYa 'U] W' Ug?cbHU_h <Y]ni b[['Y] bYH'

Heizung Spezifikation

Dimension (mm)	Länge (mm)	Material Nummer	Innerer Biege-Radius R
ø 6.4	250 - 2300	Stahl ČSN 11343 Edelstahl DIN 1.4301, 1.4404. 1.4541, 1.4828, 1.4876	min. R 10
ø 8.5	250 - 8300	Stahl ČSN 11343 Edelstahl DIN 1.4301, 1.4404. 1.4541, 1.4828, 1.4876 Kupfer Cu-DHP	min. R 10 (abhängig von der Wandstärke)
6.2 x 11.5	150 - 4500	Stahl ČSN 11343 Edelstahl DIN 1.4541 Kupfer Cu-DHP	min. R 10, flach Biegung R 20
5.5 x 13,0	150 - 4500	Stahl ČSN 11343 Edelstahl DIN 1.4541 Kupfer Cu-DHP	min. R 10, flach Biegung R 20
6.0 x 15	150 - 4500	Stahl ČSN 11343 Edelstahl ČSN 17248 Kupfer Cu-DHP	min. R 10, flach Biegung R 20
ø 10.0 *	60 - 160	Edelstahl DIN 1.4541	kann nicht gebogen werden
ø 12.5 *	60 - 160	Edelstahl DIN 1.4541	kann nicht gebogen werden
ø 12.0 **	400 - 1100	Edelstahl DIN 1.4541	kann nicht gebogen werden

* Nur für die Beheizung von Kunststoffformen, Heizung von Maschinen und deren Zubehör ** Nur für die Beheizung von Wasser in Heizkörpern und Badheizugen

Spezifische Belastung der Manteloberfläche

Anwendung	maximale Temperatur (°C)	max. spezifische Oberfläche Belastung (W/cm ²)						Kupfer Cu-DHP
		Stahl 11343 St 34-2	Stahl 17240 1.4301 AISI 304	Stahl 17349 1.4404 AISI 316L	Stahl 17246 1.4541 AISI 321	Stahl 17251 1.4828 AISI 302B	Stahl Incol. 800 1.4876	
Stehendes Wasser	100			10	10			10
Drehende Wasser (Waschmaschine)	100			14	14			14
Fließende Wasser (Durchlauferhitzer)	60			25	30			25
Druckwassersystem	200			10	10			10
Alkalien Bad	100	6		8	8			
Chlorwasser	100			10			10	
Säurebäder	100			2			2,5	
Phosphatierbäder	100			4	4			
Leicht Öl	250	2			2			
Schweröl	100	1,5			1,5			
Frittieröl	250			5	5			
Öl Radiator	80	6			6			
Asphalt	100	1			1			
Glycerin	150	2			2			
Leitung	500				4			
Luft	50	1,5	5		5	6	6	
	200-450		4		4	5	5	
strömende Luft 5 m/s	50	3	8		8	9	10	
	200	1,5	5		5	7	7,5	
strömende Luft 10 m/s	5	5	10		10	10	10	
	200	2	8		8	9	9	
	450	-	4		4	6	6	
Speicher Herd	600	-	4	-	4	4	4	
Kontaktheizung	300	2	4	-	4	6	6	
Gießen von Gussteilen	300	18	18	-	18			

Maximale spezifische Belastung von flach-ovale Profile bis 3 W/cm² begrenzt ist, mit einer Ausnahme von gegossenen Elemente (zB aus Aluminium), kann die spezifische Belastung höher sein.

Unser Qualitätsanspruch

Im Mittelpunkt der Firmenphilosophie stehen

- Hohe Qualität,
 - Kompetente Beratung der Kunden sowie
 - Der ständige Ausbau der Forschungs- und Entwicklungskapazitäten,
- * Für Satz- und Druckfehler wird keine Haftung übernommen
- * Änderungen Vorbehalten



Our quality standards

The focus of the company philosophy

- High quality,
 - Competent advice to customers as well
 - The constant expansion of research and development capacities,
- * No liability is assumed for typographical and printing errors
- * Subject to change



ELKUME e.U, Am Graben 8, 2011 Unterhautzentral, Österreich
Tel. +43 (0)676 78 22 974 office@elkume.at www.elkume.at